

MARINE PRODUCT DATA SHEET

OEM: 357-103-00 (1100 GPH)
AFTERMARKET: 357-103-10 (1100 GPH)

APPLICATION

12V DC Bait/Livewell tanks water circulation

PUMP

Type: Centrifugal Pump
Outlet Port: 1-1/8" Barb
Inlet Port: 3/4" NPT-M
Washdown Port: 1/2" MPT-F
Liquid: 130 °F [54 °C] Max
Prime: Flooded Inlet
Inlet PSI: 30 PSI [2.1 Bar] Max
Run Dry: No

ELECTRICAL

Motor: 12VDC Permanent Magnet,
Continuous Duty
Protection: Need External Fuse (Not supplied)
Leads: 6 ft [1.8M] Tinned, 16 AWG
Fuse: 6 Amp Recommended
Control: No Control

MATERIALS

Housing: High Strength Nylon
Impeller: High Strength Nylon
Hardware: Stainless Steel

APPROVALS

Ignition Protected 8846, CE

WARRANTY

2 Year Limited Warranty. Contact SHURflo for details

SHIPPING

Net Weight (unboxed): 1.4 Lb [0.63 Kg] each
Approx. Lbs./Ctn. 33 Lb [15 Kg]
Pumps in Carton: 24
Carton Size: 24"L x 18"W x 11" H
[61cm x 46 cm x 28 cm]

RELATED DOCUMENTS

Catalog: MS-030-140
Installation Manual: 911-611
Applications Spec Guide: MS-020-005



Everything you are looking for in a livewell pump. Our tough, high density nylon housing and heavy duty water cooled motor give the SHURflo Livewell Pumps unparalleled reliability. Patented anti-airlock feature allows the pump to clear trapped air in rough water or when the boat is anchored. The dual port fitting allows for easy washdown pump connections. All Piranha Series Livewell Pumps have a removable cartridge for easy cleaning.

Replacement Kit

94-620-00



TYPICAL PERFORMANCE

PRESSURE		FLOW		CURRENT
METERS	FT OF HEAD	GPH	LPH	AMPS
0.0	0	1185	4485	4.50
1.2	4	780	2952	4.12
1.8	6	630	2384	4.07
2.4	8	510	1930	3.93
4.6	15	0.0	0.0	3.27

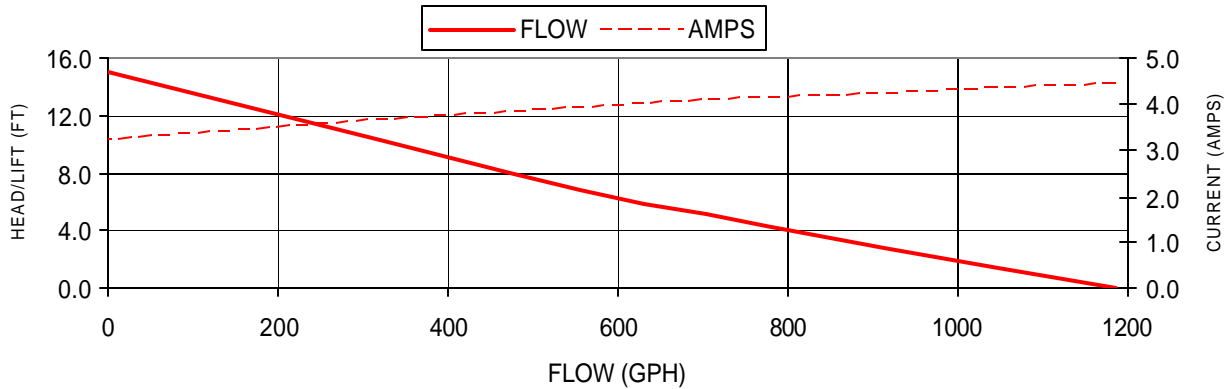

DIMENSIONS [mm]

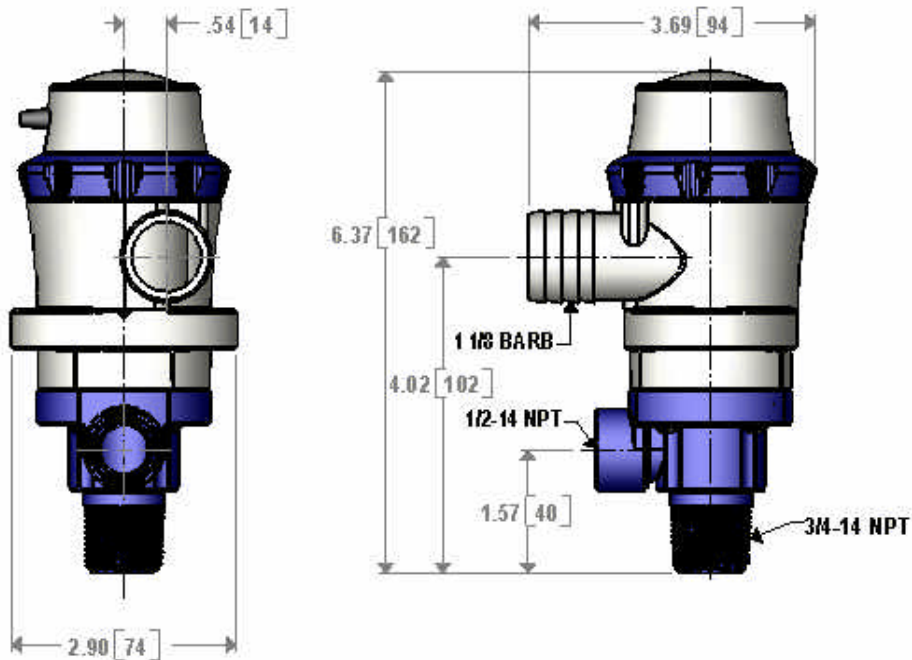

Visit our Web Site at <http://www.shurflo.com>
 Shurflo reserves the right to update specifications,
 change prices, or make substitutions without notice.

SHURflo
 5900 Katella Avenue
 Cypress, CA 90630
 Phone (562) 795-5200
 Toll Free (800) 854-3218
 Fax (562) 795-7564

SHURflo East
 52748 Park Six Court
 Elkhart, IN 46514-5427
 Phone (562) 795-5200
 Toll Free (800) 854-3218
 Fax (574) 264-2169

SHURflo Europe, Middle East, Africa
 Pentair Water Belgium bvba
 Industriepark Wolfstee, Toekomstlann 30
 B-2200 Herentals, Belgium
 Phone +32-14-283500
 Fax +32-14-283505



Pentair Water

FLOW TECHNOLOGIES GROUP
 5900 Katella Ave, Cypress, CA 90630
 Phone (800) 854-3218 • (562) 795-5200 • Fax (562) 795-7564
www.shurflo.com